



Compressor Selection: Semi-hermetic Reciprocating Compressors

Input Values

Compressor model	(4J-22.2Y)	Suction gas temperature	20,00 °C
Mode	Refrigeration and Air conditioning	Operating mode	Auto
Refrigerant	R404A	Power supply	400V-3-50Hz
Reference temperature	Dew point temp.	Capacity Control	100%
Liq. subc. (in condenser)	0 K	Useful superheat	100%

Result

Q [W]	Cooling capacity	COP [-]	COP/EER
Q* [W]	Cooling capacity *	COP* [-]	COP/EER *
P [kW]	Power input	m [kg/h]	Mass flow
I [A]	Current	Op.	Operating mode
Qc [W]	Condenser Capacity	th [°C]	Discharge gas temp. w/o cooling

tc	to	10°C	0°C	-10°C	-20°C	-30°C	-40°C	-50°C	-60°C
30°C	Q [W]	--	60134	41180	26972	16485	8918	--	--
	Q* [W]	--	60134	41180	26972	16485	8918	--	--
	P [kW]	--	13,10	12,11	10,46	8,37	6,05	--	--
	I [A]	--	22,8	21,3	19,10	16,51	14,06	--	--
	Qc [W]	--	73233	53288	37429	24851	14970	--	--
	COP [-]	--	4,59	3,40	2,58	1,97	1,47	--	--
	COP* [-]	--	4,59	3,40	2,58	1,97	1,47	--	--
	m [kg/h]	--	1529	1024	661	399	214	--	--
	Op.	--	Standard	Standard	Standard	Standard	Standard	--	--
	th [°C]	--	62,4	75,9	91,2	109,7	134,6	--	--
40°C	Q [W]	--	51467	35094	22774	13672	7114	--	--
	Q* [W]	--	51467	35094	22774	13672	7114	--	--
	P [kW]	--	15,49	13,69	11,37	8,74	6,01	--	--
	I [A]	--	26,3	23,6	20,3	16,94	14,03	--	--
	Qc [W]	--	66956	48786	34143	22408	13129	--	--
	COP [-]	--	3,32	2,56	2,00	1,56	1,18	--	--
	COP* [-]	--	3,32	2,56	2,00	1,56	1,18	--	--
	m [kg/h]	--	1476	982	627	372	191,7	--	--
	Op.	--	Standard	Standard	Standard	Standard	Standard	--	--
	th [°C]	--	73,5	87,0	102,4	121,1	0	--	--
50°C	Q [W]	--	42871	29112	18723	11054	5563	--	--
	Q* [W]	--	42871	29112	18723	11054	5563	--	--
	P [kW]	--	17,85	15,26	12,28	9,12	6,00	--	--
	I [A]	--	30,0	26,0	21,6	17,40	14,01	--	--
	Qc [W]	--	60719	44371	31000	20172	11561	--	--
	COP [-]	--	2,40	1,91	1,53	1,21	0,93	--	--
	COP* [-]	--	2,40	1,91	1,53	1,21	0,93	--	--
	m [kg/h]	--	1428	943	594	346	172,4	--	--
	Op.	--	Standard	Standard	Standard	Standard	Standard	--	--
	th [°C]	--	85,1	98,7	114,4	133,5	0	--	--

-- No calculation possible (see message in single point selection)

*According to EN12900 (20°C suction gas temp., 0K liquid subcooling)

Application Limits 100%

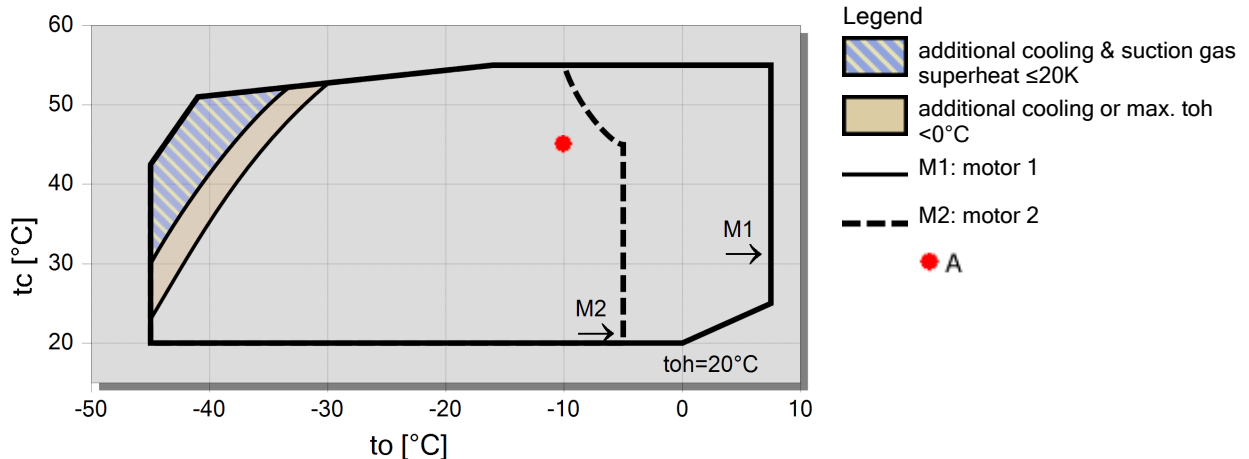



Technical Data: (4J-22.2Y)

Dimensions and Connections

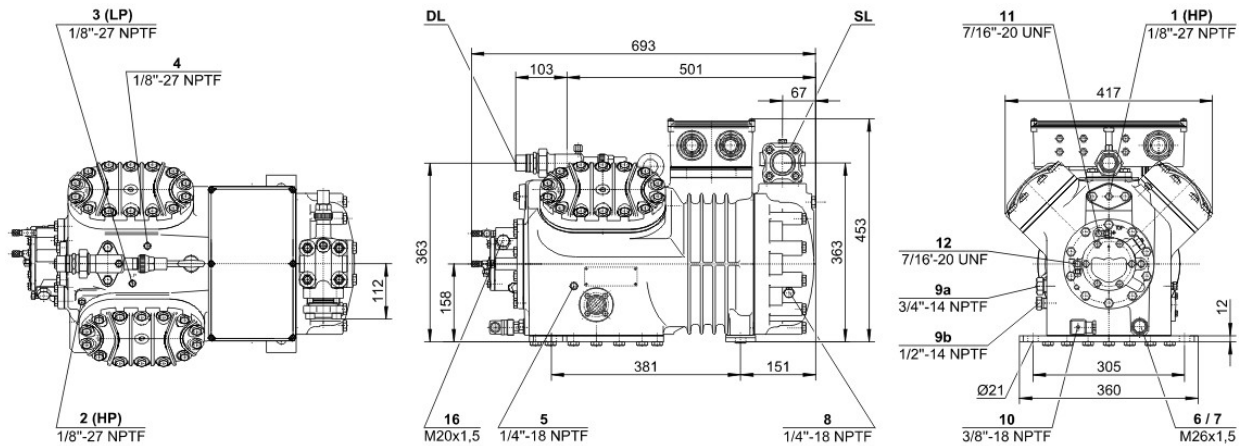

Technical Data

Technical Data

Displacement (1450 RPM 50Hz)	63,5 m ³ /h
Displacement (1750 RPM 60Hz)	76,64 m ³ /h
No. of cylinder x bore x stroke	4 x 65 mm x 55 mm
Weight	190 kg
Max. pressure (LP/HP)	19 / 28 bar
Connection suction line	42 mm - 1 5/8"
Connection discharge line	28 mm - 1 1/8"
Connection cooling water	R 3/4"
Oil type R134a/R407C/R404A/R507A/R407A/R407F	tc<55°C: BSE32 / tc>55°C: BSE55 (Option)
Oil type R22 (R12/R502)	B5.2 (Standard)
Oil type R290/R1270	SHC226E (Standard)

Motor data

Motor voltage (more on request)	380-420V PW-3-50Hz
Max operating current	39.0 A
Winding ratio	50/50
Starting current (Rotor locked)	97.0 A Y / 158.0 A YY
Max. Power input	21,5 kW

Extent of delivery (Standard)

Motor protection	SE-B2
Enclosure class	IP54 (Standard), IP66 (Option)
Vibration dampers	Standard
Oil charge	4,00 dm ³

Available Options

Discharge gas temperature sensor	Option
Start unloading	Option
Capacity control	100-50% (Option)
Additional fan	Option
Water-cooled cylinder heads	Option
Oil service valve	Option
Crankcase heater	140 W (Option)
Oil pressure monitoring	MP54 (Option), Delta-PII (Option, not for R290/R1270)

Sound measurement

Sound power level (+5°C / 50°C)	75,0 dB(A) @ 50Hz
Sound power level (-10°C / 45°C)	77,5 dB(A) @ 50Hz
Sound power level (-35°C / 40°C)	(81,0) dB(A) @ 50Hz
Sound pressure level @ 1m (+5°C / 50°C)	67,0 dB(A) @ 50Hz
Sound pressure level @ 1m (-10°C / 45°C)	69,5 dB(A) @ 50Hz
Sound pressure level @ 1m (-35°C / 40°C)	(73,0) dB(A) @ 50Hz



Compressor Selection: Semi-hermetic Reciprocating Compressors

Input Values

Compressor model Mode	(4Z-8.2Y) Refrigeration and Air conditioning	Suction gas temperature Operating mode	20,00 °C Auto
Refrigerant Reference temperature Liq. subc. (in condenser)	R404A Dew point temp. 0 K	Power supply Capacity Control Useful superheat	400V-3-50Hz 100% 100%

Result

Q [W] Qu* [W] P [kW] I [A] Qc [W]	Cooling capacity Evaporator capacity Power input Current Condenser Capacity	COP [-] m [kg/h] Op. th [°C]	COP/EER Mass flow Operating mode Discharge gas temp. w/o cooling
---	---	---	---

tc	to	-5°C	-10°C	-15°C	-20°C	-25°C	-30°C	-35°C	-40°C
30°C	Q [W]	22232	18280	14862	11917	9392	7240	5419	3889
	Qu* [W]	22232	18280	14862	11917	9392	7240	5419	3889
	P [kW]	5,56	5,26	4,92	4,54	4,10	3,62	3,09	2,50
	I [A]	10,21	9,78	9,31	8,79	8,23	7,63	7,00	6,37
	Qc [W]	27790	23540	19782	16453	13497	10864	8507	6386
	COP [-]	4,00	3,47	3,02	2,63	2,29	2,00	1,75	1,56
	m [kg/h]	558	455	367	292	229	175,4	130,7	93,5
	Op.	Standard	Standard	Standard	Standard	Standard	Standard	Standard	Standard
	th [°C]	68,4	75,1	82,3	90,3	99,1	108,7	119,0	129,6
	40°C	Q [W]	19004	15538	12536	9950	7732	5845	4251
Qu* [W]		19004	15538	12536	9950	7732	5845	4251	2916
P [kW]		6,35	5,91	5,42	4,88	4,30	3,68	3,03	2,35
I [A]		11,35	10,71	10,01	9,26	8,48	7,69	6,93	6,22
Qc [W]		25355	21450	17957	14830	12031	9523	7276	5262
COP [-]		2,99	2,63	2,31	2,04	1,80	1,59	1,40	1,24
m [kg/h]		538	435	348	274	211	158,9	115,0	78,6
Op.		Standard	Standard	Standard	Standard	Standard	Standard	Standard	Standard
th [°C]		79,0	85,9	93,3	101,4	110,2	119,9	130,6	0
50°C		Q [W]	15501	12601	10082	7905	6035	4442	3095
	Qu* [W]	15501	12601	10082	7905	6035	4442	3095	1968
	P [kW]	7,13	6,52	5,86	5,16	4,44	3,71	3,00	2,30
	I [A]	12,51	11,60	10,64	9,64	8,66	7,74	6,90	6,18
	Qc [W]	22632	19121	15940	13064	10475	8155	6091	4270
	COP [-]	2,17	1,93	1,72	1,53	1,36	1,20	1,03	0,85
	m [kg/h]	508	408	323	251	190,1	139,0	96,3	61,0
	Op.	Standard	Standard	Standard	Standard	Standard	Standard	Standard	Standard
	th [°C]	91,0	98,1	105,7	114,1	123,5	134,6	0	0

-- No calculation possible (see message in single point selection)

*According to EN12900 (20°C suction gas temp., 0K liquid subcooling)

Application Limits 100%

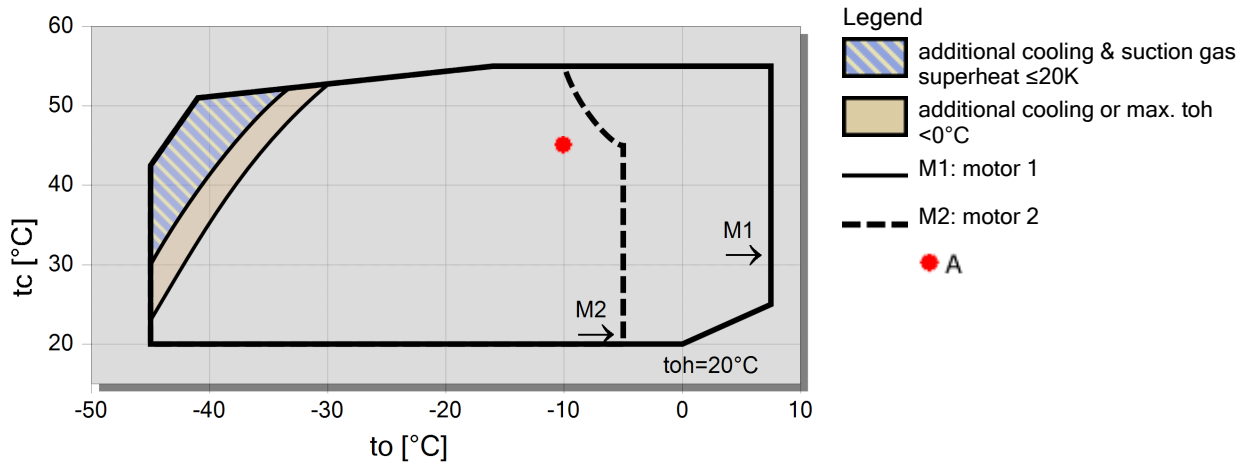



Technical Data: (4Z-8.2Y)

Dimensions and Connections

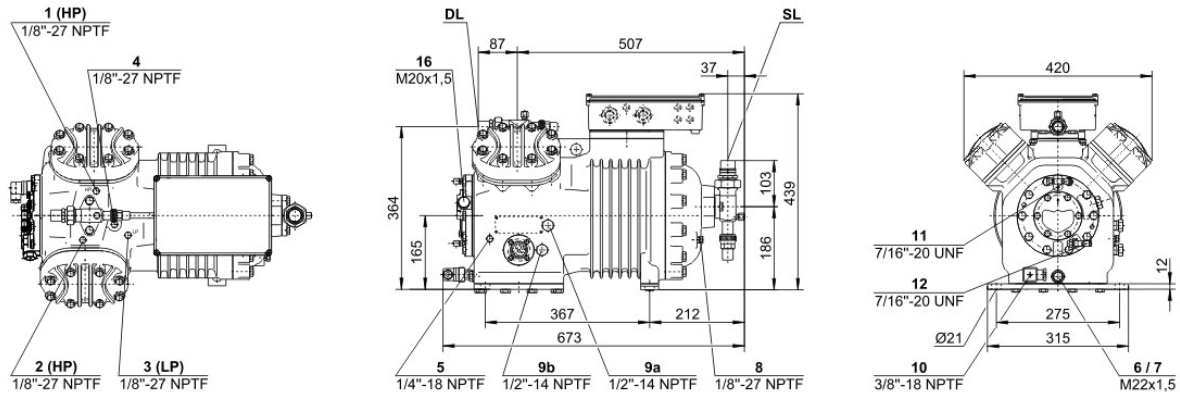

Technical Data

Technical Data

Displacement (1450 RPM 50Hz)	28,11 m³/h
Displacement (1750 RPM 60Hz)	33,93 m³/h
No. of cylinder x bore x stroke	4 x 55 mm x 34 mm
Weight	140 kg
Max. pressure (LP/HP)	19 / 28 bar
Connection suction line	28 mm - 1 1/8"
Connection discharge line	22 mm - 7/8"
Connection cooling water	R 1/2"
Oil type R134a/R407C/R404A/R507A/R407A/R407F	tc<55°C: BSE32 / tc>55°C: BSE55 (Option)
Oil type R22 (R12/R502)	B5.2 (Standard)
Oil type R290/R1270	SHC226E (Standard)

Motor data

Motor voltage (more on request)	380-420V PW-3-50Hz
Max operating current	17.0 A
Winding ratio	50/50
Starting current (Rotor locked)	49.0 A Y / 81.0 A YY
Max. Power input	9,7 kW

Extent of delivery (Standard)

Motor protection	SE-B2
Enclosure class	IP54 (Standard), IP66 (Option)
Vibration dampers	Standard
Oil charge	3,00 dm³

Available Options

Discharge gas temperature sensor	Option
Start unloading	Option
Capacity control	100-50% (Option)
Additional fan	Option
Water-cooled cylinder heads	Option
Oil service valve	Option
Crankcase heater	100 W (Option)
Oil pressure monitoring	MP54 (Option), Delta-PII (Option, not for R290/R1270)

Sound measurement

Sound power level (+5°C / 50°C)	74,0 dB(A) @ 50Hz
Sound power level (-10°C / 45°C)	74,0 dB(A) @ 50Hz
Sound power level (-35°C / 40°C)	(80,0) dB(A) @ 50Hz
Sound pressure level @ 1m (+5°C / 50°C)	66,0 dB(A) @ 50Hz
Sound pressure level @ 1m (-10°C / 45°C)	66,0 dB(A) @ 50Hz
Sound pressure level @ 1m (-35°C / 40°C)	(72,0) dB(A) @ 50Hz